

# Power clamp cylinder

## JSK Series

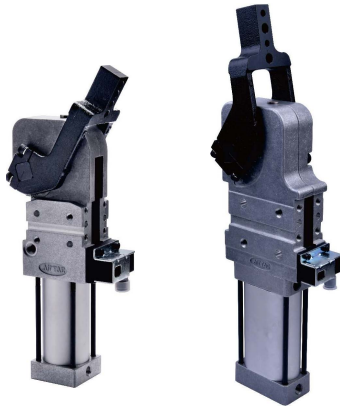

### Specification

Model	JSK40	JSK50	JSK63	JSK80
Output torque (0.5MPa)	120N.m	160N.m	380N.m	800N.m
Acting type	Double acting			
Fluid	Air(to be filtered by 40μm filter element)			
Operating pressure	0.3~0.8MPa(43~116psi)			
Proof pressure	1.2MPa(175psi)			
Temperature	-20~70 °C			
Opening angle	5°~135°			
Minimum opening and closure time	1 second clamping, 1 second opening			
Position sensing	Electrical Inductive approaching sensor			
Cushion type	Air buffer			
Weight [Note1]	2.0kg	3.7kg	5.0kg	11.5kg
Port size [Note2]	1/8"	1/4"		

[Note1] This weight includes 15mm offset clamping arm;

[Note2] G thread is available.

### Ordering code

JSK □ 50 AM1R K G □

① ② ③ ④ ⑤ ⑥ ⑦

① Model	② Clamping arm position	③ Bore size	④ Clamping arm [Note2]	⑤ Sensor switch [Note3]	⑥ Thread type	⑦ Port
JSK: Power clamp cylinder	Blank: Horizontal 	40 (circular)	Blank: No clamping arm AM1: Offset 15mm 	Blank: No sensor switch K: With electrical sensor switch (PNP) KN: With electrical sensor switch (NPN)	G: G	Blank 
	V: Vertical 		AM3: Offset 45mm 			B 
		50(oval) 63(oval) 80(oval)	Blank: No clamping arm AM1: Offset 15mm 			Blank 
			AM3: Offset 45mm 			B 
			AM2: Offset 15mm 			Port 
			AM4: Offset 45mm 			Port 

[Note1] Please refer to the right table for details of max. opening angle.

[Note2] Please refer to the drawing for detailed dimensions of clamping arm. products come with opening angle of 90°.

[Note3] K/KN type sensor switch can be ordered separately and please refer to relative contents.

Bore size	Arm position	Arm type	Maximum opening angle	Bore size	Arm position	Arm type	Maximum opening angle
40	horizontal	AM1	135°	50 63 80	horizontal	AM1, AM3	135°
		AM3	105°			AM2, AM4	
	Vertical(V)	AM1	120°		Vertical(V)	AM1, AM3	105°
		AM3	105°			AM2, AM4	

### Instructions

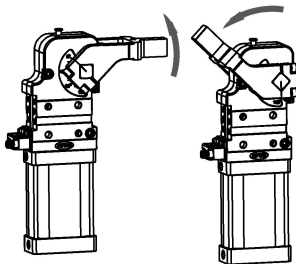

Step1: Adjust the clamping arm to the maximum opening angle;

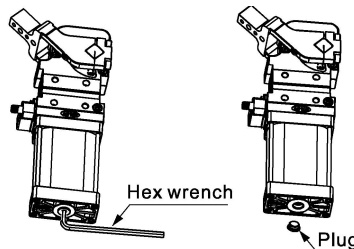

Step2: Unscrew the plug by H6(40) or H8(50,63,80) hex wrench;

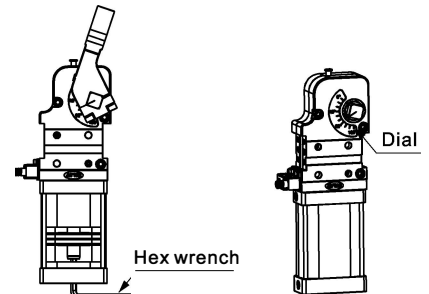

Step3: Adjust the clamping arm to the desired opening angle by H6(40) or H8(50,63,80) hex wrench.

#### Instructions

1. Cushioning body and piston are connected by thread and riveting.
2. Inductive block is fixed on the piston rod, which will move with piston rod while adjusting.
3. Sensor switch does not need further adjustment after finishing the angle adjustment.

# Power clamp cylinder

## JSK Series

### Inner structure and material of major parts

NO.	Item	Material	NO.	Item	Material
1	Plug	Carbon steel	14	Retaining pin	Carbon steel
2	Back cover	Aluminum alloy	15	Connecting rod	Alloy steel
3	Aluminum barrel	Aluminum alloy	16	Clamping arm	Carbon steel
4	Cushion body	Carbon steel	17	Pivot	Alloy steel
5	Piston	Aluminum alloy+NBR	18	Bushing	Alloy steel
6	Front cover	Aluminum alloy	19	Piston rod	Carbon steel
7	Sensor switch		20	End cap	Aluminum alloy
8	Sensor switch fix	Plastic	21	Spool O-ring	TPU
9	Joint	Alloy steel	22	Spring	Spring steel
10	Inductive block	Carbon steel	23	Steel ball	Stainless steel
11	I Knuckle	Alloy steel	24	Cushing O-ring	TPU
12	Strengthen steel plate	Alloy steel	25	O-ring	NBR
13	Bushing	Alloy steel			

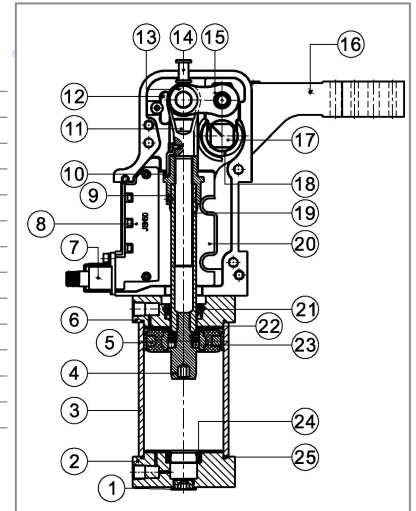

### Dimensions

#### JSK40AM1

#### Horizontal clamping position

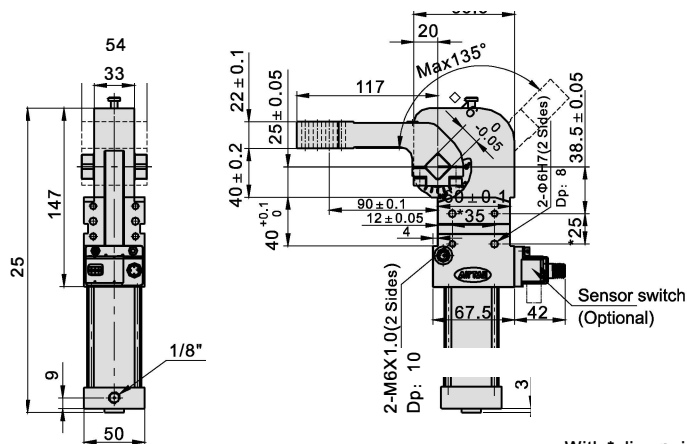

#### Vertical clamping position

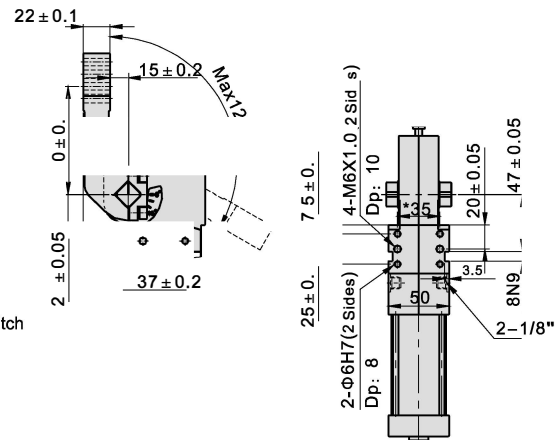

With \* dimension: Pin hole position tolerance:  $\pm 0.02$ . Thread hole position tolerance:  $\pm 0.1$ .

#### JSK40AM3

#### Horizontal clamping position

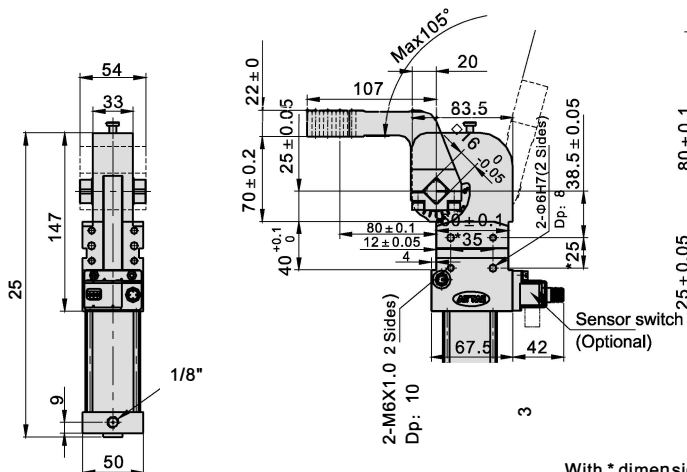

#### Vertical clamping position

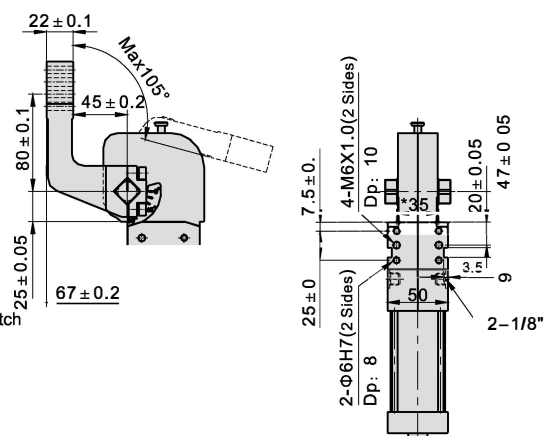

With \* dimension: Pin hole position tolerance:  $\pm 0.02$ . Thread hole position tolerance:  $\pm 0.1$ .

# Power clamp cylinder

## JSK Series

### JSK50AM1(2)

Horizontal clamping position

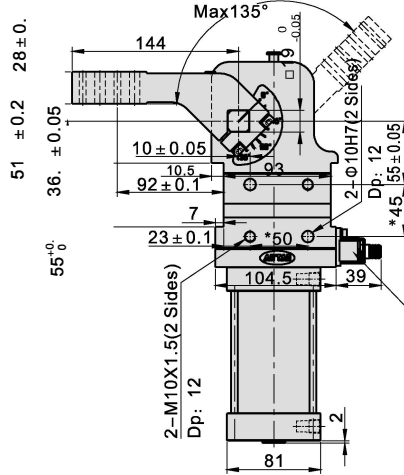
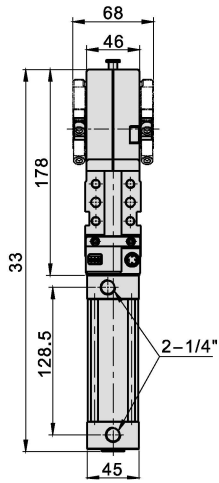

Vertical clamping position

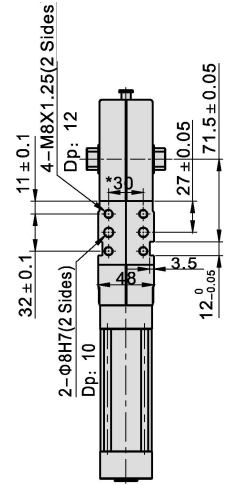
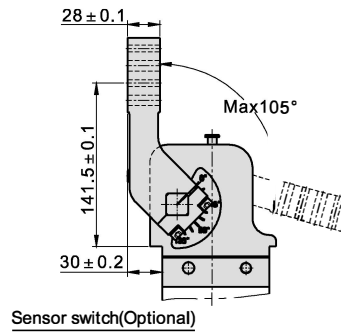

With \* dimension: Pin hole position tolerance:  $\pm 0.02$ . Thread hole position tolerance:  $\pm 0.1$ .

### JSK50AM3(4)

Horizontal clamping position

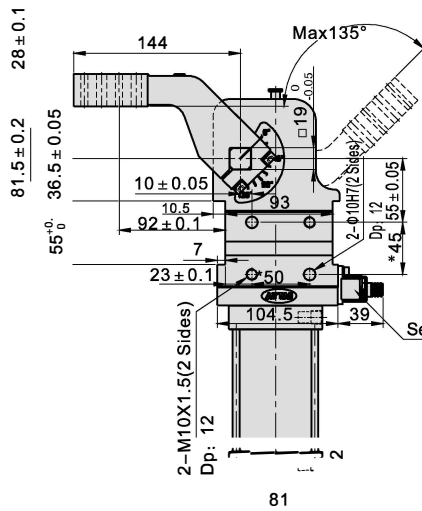
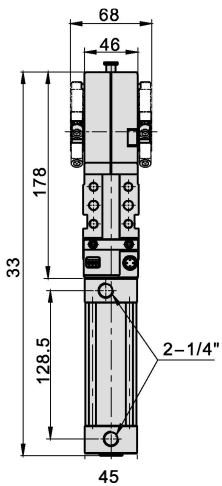

Vertical clamping position

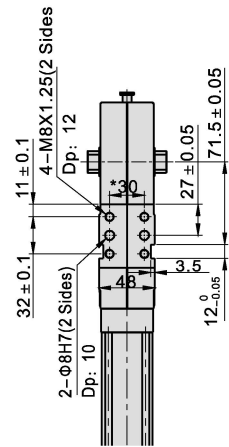
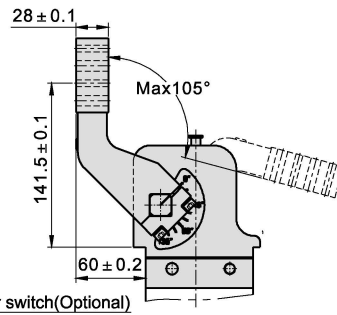

With \* dimension: Pin hole position tolerance:  $\pm 0.02$ . Thread hole position tolerance:  $\pm 0.1$ .

# Power clamp cylinder

## JSK Series

### JSK63AM1(2)

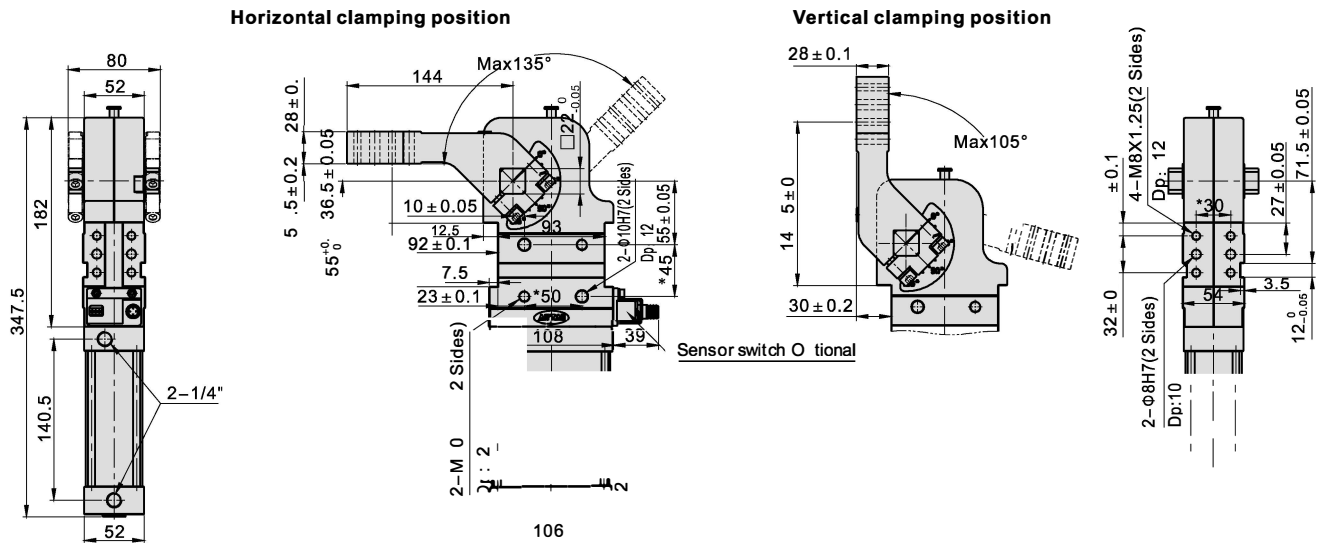

With \* dimension: Pin hole position tolerance: ±0.02. Thread hole position tolerance: ±0.1.

### JSK63AM3(4)

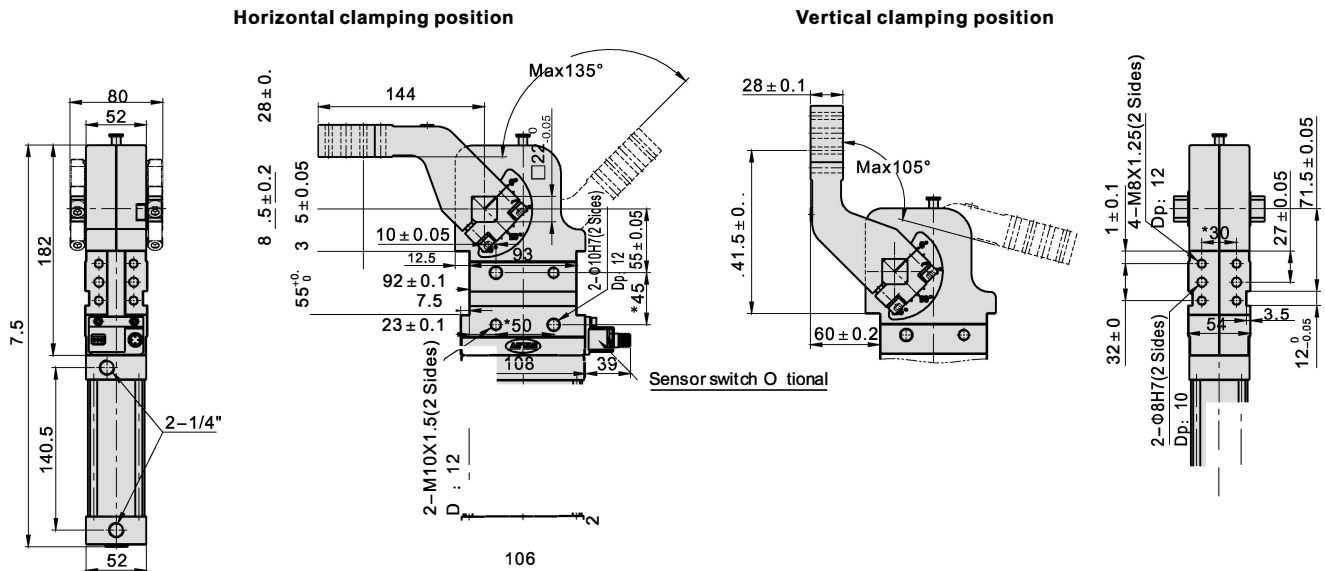

With \* dimension: Pin hole position tolerance: ±0.02. Thread hole position tolerance: ±0.1.

# Power clamp cylinder

## JSK Series

### JSK80AM1(2)

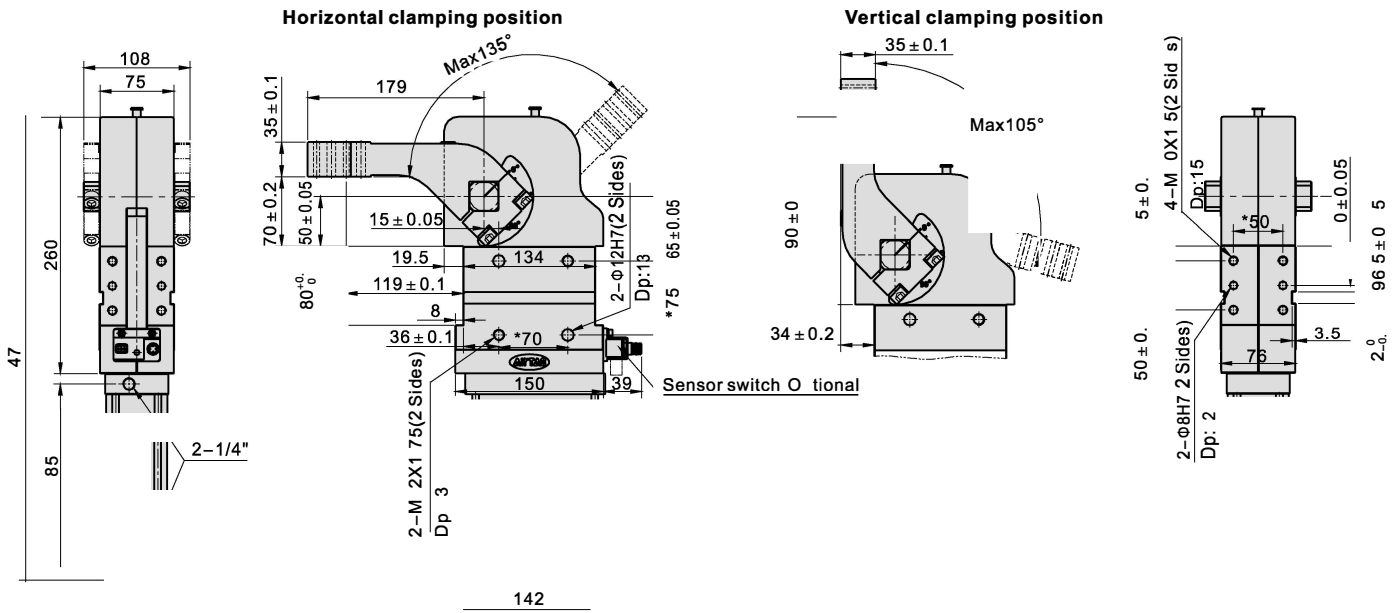

With \* dimension: Pin hole position tolerance: ±0.02. Thread hole position tolerance: ±0.1.

### JSK80AM3(4)

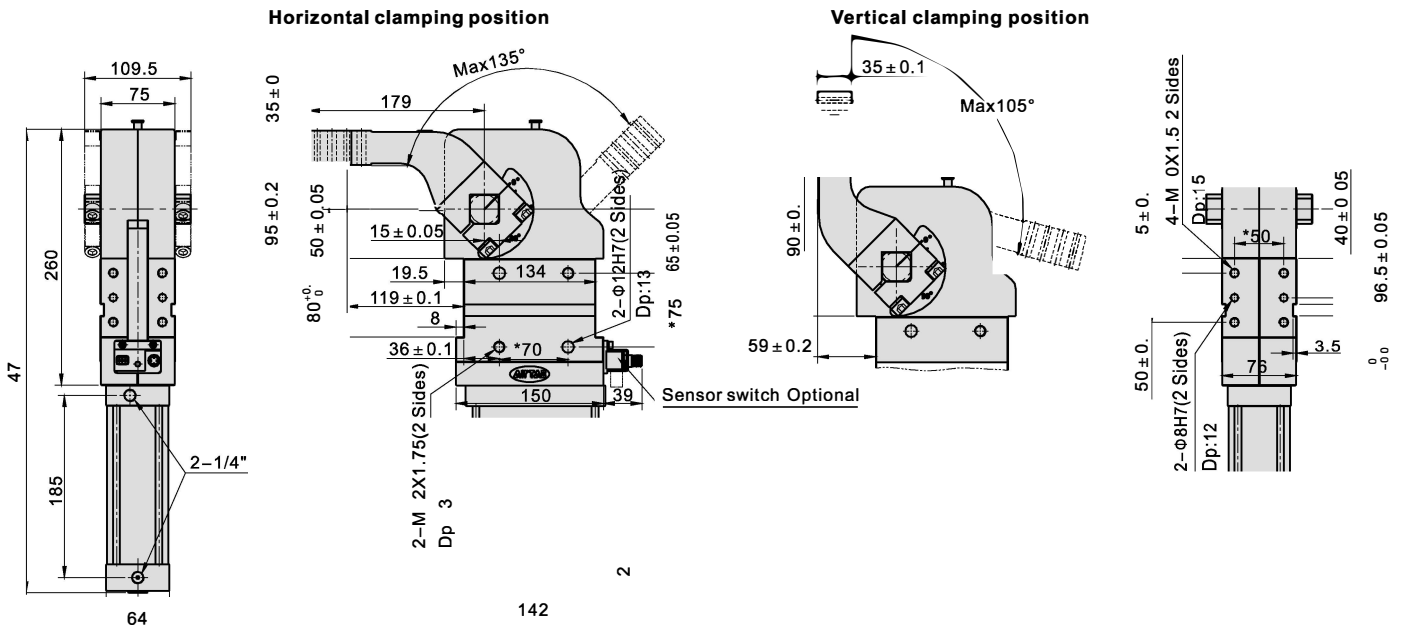

With \* dimension: Pin hole position tolerance: ±0.02. Thread hole position tolerance: ±0.1.